

# Adaptation of Graphical Data in Collaborative Environment

*Martin Klima, Zdenek Mikovec, Pavel Slavik*

Dept. of Computer Science and Engineering, Czech Technical University in Prague  
Karlovo nam. 13, Praha 2,  
Czech Republic

xklima@fel.cvut.cz, xmikovec@fel.cvut.cz, slavik@fel.cvut.cz

**Abstract.** The theme of adaptation of data that were originally designed for desktop computers is discussed. The introduced system should modify these data for use in mobile environment with respect to the actual context (device, situation, location etc.). System architecture for data adaptation in a collaborative environment is introduced and different approaches to possible solution are discussed. The introduced adaptation is context sensitive, therefore each user involved in the collaboration may get data with different representation. This may lead to misunderstandings during the communication. Solution of this problem is the use of classes of perception equivalence. Classes of perception equivalence, as described in the paper, define range of data representation parameters with the same information content. Special attention is paid to determining the appropriate visual data presentation.

## 1. INTRODUCTION

Mobile (PDA) devices are becoming a part of the everyday live similar to mobile phones. Demands to their functionality are growing hand in hand with their capabilities. One of the new requirements is a real-time coordination of actions and mobile knowledge management. Collaboration in terms of real time data and workspace sharing becomes a hot topic. There are already several systems that bring this functionality to the PDA platform. The mobile devices nevertheless suffer with some performance, memory and software compatibility problems. Therefore there are systems that modify data originally designed for desktop computers to be usable on mobile devices. One of the methods is called adaptation. The adaptation as well as collaboration is currently solved independently. The conjunction of these two functionalities is a topic of this work.

We introduce methods for enriching the adaptation process to enable collaborative work in mobile environment. Our technique enables to perform the adaptation separately for each user in a context-sensitive manner while ensuring cognitive compatibility of the result. This way we are bringing context-aware adaptation into distributed heterogeneous collaborative environment.

## 2. GOALS

The goal of this work is to enable sharing of data in mobile environment. The users are in general using various kinds of mobile devices starting from smart phones, PDAs (Personal Digital Assistant) and ending by tablet PCs. The context of use [Tazari 2003] consisting of the user's personal profile, location, terminal and other profiles is unique to each of the collaboration participants. The system should be able to automatically adapt the original data to the current needs of each of the user while maintaining QoP (Quality of Presentation) as high as possible. Due to the collaborative aspect of the adaptation, the result must contain qualitatively same information for each of the participants. We are primarily focusing to SVG (Scalable Vector Graphics) data format that is developed for presentation of 2D graphics on the Internet.

## 3. USE CASE

In our scenario we have two users that collect data in some outdoor construction site. In the first step they need to browse the 2D data. Before the data can be displayed on the end-device, they need to be processed by the adaptation engine on the server. In this model use

case one of the users has a color-enabled device with 128 MB of free memory while the other grayscale enabled device with only 8MB of free memory. The single user adaptation for both users is displayed in Figure 1.

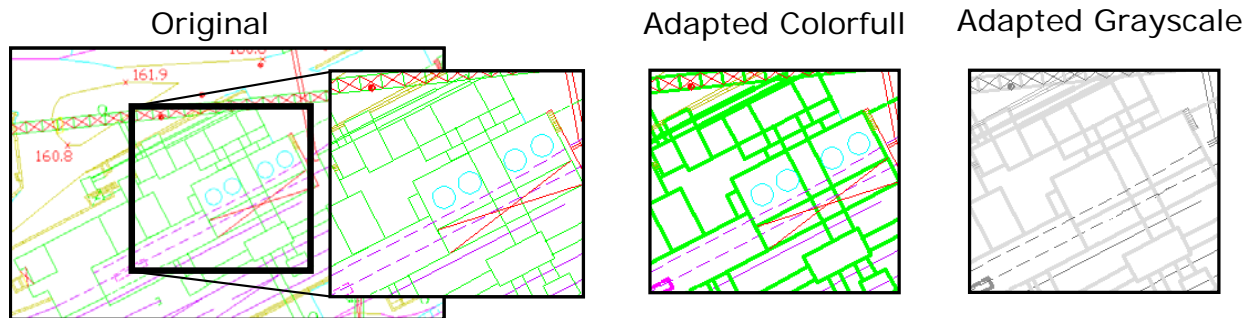

**Figure 1 Single user adaptation result**

If the users identify a problem, they need to start a collaborative session to consult the problem with other experts. In this moment the system will try to find graphical representation of the data that will be suitable for inter-user communication. The system will try to represent the color information by another visual attribute, in this case a line style and will render the same objects on all shared data copies. An example of the original and adapted data in collaborative mode can be seen in Figure 2. The users get all the necessary information from the adapted data in different representation which is cognitively equivalent and can therefore collaborate with each other.

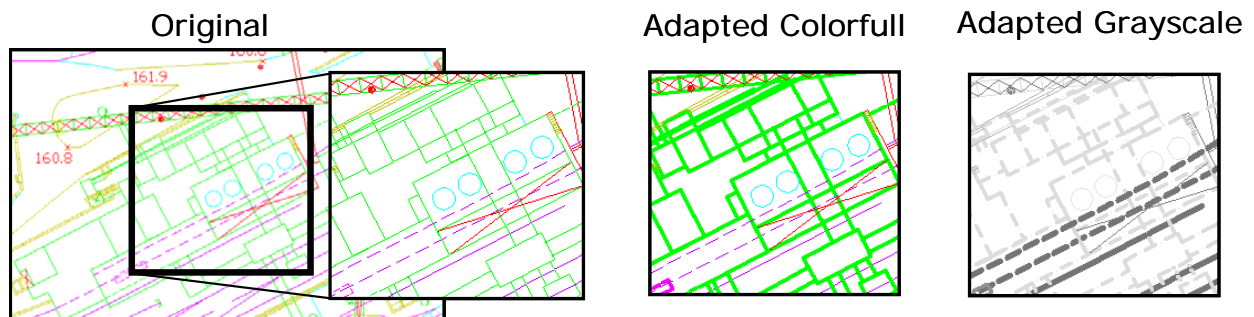

**Figure 2 Original and adapted data in collaborative scenario**

#### 4. PROBLEMS TO SOLVE

In the heterogeneous mobile environment the requirements to adaptation vary according to the device used, current location, time, user preferences and other conditions. Set of values describing this state is called context of use. This means that generally each single user should get adapted data where the adaptation is based on different starting conditions. This is acceptable (and desired) in a single-user scenarios.

- In case of mobile data sharing and collaboration the adaptation methods for single user [Rauschenbach 1998][Blair 2000] scenario fail [Klima 2002]. In this case the adaptation must be controlled with respect to the context of use and cognitive possibilities of *all other* collaborating participants. The cognitive possibilities, same as the adaptation process, are context sensitive. We introduce architecture of the adaptation unit and method for controlling the adaptation in the collaborative environment.

- All collaborating users must get cognitively equivalent presentation of data. The identification of the presentation parameters is the main problem.

## 5. SOLUTION

In this section we will first introduce the adaptation process for a single user scenario and then the enhancement for multi user collaborative scenario.

### 5.1 Single user adaptation process

The adaptation process can be divided into several steps. Each step solves an independent task and can be therefore performed in a separate unit. The steps can be performed in an adaptation pipeline or can be distributed on several machines. The adaptation pipeline is displayed in Figure 3.

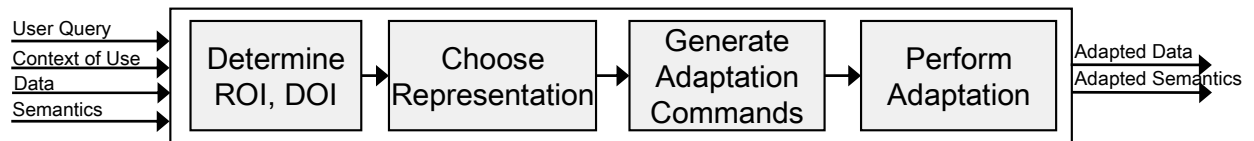

**Figure 3** Adaptation pipeline

There are four inputs into the adaptation unit. The first input is the user's query where preferred parameters of the adaptation are specified. These parameters will take precedence over those derived from the *context of use*. Second input is the *context of use*. This is a set of values describing the user's personal data, parameters of the terminal currently used, profile of the location, environment and more. See [Tazari 2003] for more details about the *context of use*. The third input is the data to be adapted itself and the fourth the semantic description of this data. The semantics (if available) serves for description of those aspects of the data that cannot be expressed in the data native format. We use the following formats for the semantics: MPEG-7, RDF, OWL.

#### 5.1.1. Determining of RoI and DoI

Region of Interest (RoI) is a part of the data that have high significance for the user in the current context of use. The determination of RoI **is not the subject of this paper**. To measure the significance of RoI we use a Degree of Interest (DoI) index. The source data are divided in into elementary information items and DoI is computed for each of them. The DoI index is a function of input information item, input semantics and context of use.

$DoI_n = f(\text{inf\_item}_n, \text{semantics}_{n+\text{surrounding}}, \text{context\_of\_use}, \text{user\_query})$  Information items with DoI higher than given threshold (constant value) are within the RoI.

#### 5.1.2. Choosing representation

The goal of adaptation is to change the representation of the data to match the context of use. An example of changing the representation is change of image resolution, change of color depth or change representation of color-based information to line-style-based information as seen in Figure 2.

In this step of the adaptation the representation style for each information item of the data is determined.

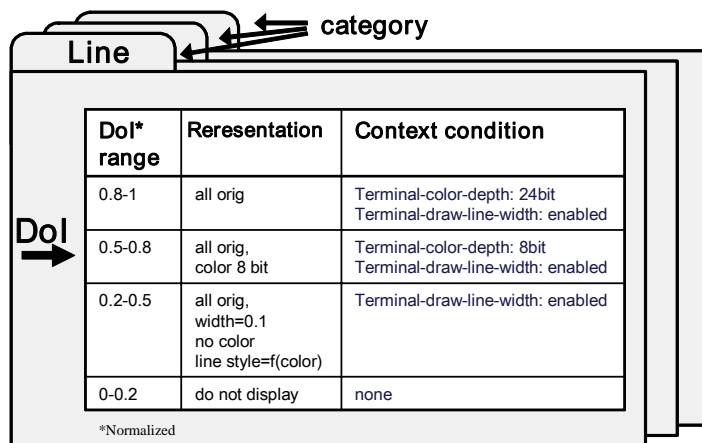

**Figure 4 Choosing representation**

In Figure 4 it is schematically displayed how representation parameters are determined. For given data format we define separate categories for elementary information items. In the case of 2D vector graphics this may be for example line, oval, polygon, polyline, text etc. For each of these categories there is a representation table as seen in Figure 4. Based on the DoI the appropriate line of the representation table is selected starting from the top. To accept the line, the context conditions must be satisfied. If this is not the case, searching will continue in the lines below.

The information item category has a set of attributes. How (if at all) they will be changed is given in the Representation column of the table. This change is in fact a set of functions that make a projection of current attributes to the new adapted space. The simplest projection is one to one, e.g. no change of this attribute. Color depth reduction is an example of more complicated projection where RGB space1 is projected to RGB space2. Finally a qualitative representation change may be defined as shown in line 3 of the table. Value of one attribute is there overridden by newly generated one. In this case it is the line style (broken line) that is generated as a function of the original line color.

Using this scheme we can determine the representation styles of all the information items within the input data. Notice that we do not use the semantic description directly anymore. They were used for determining the DoI which is influencing the result of choosing of representation of each information item.

The adaptation commands and Choosing representation tables are data type specific. Therefore it is not easy to build a general system able to process any type of data. In our approach we have defined an abstract data model that defines structure and properties of the data.

We are currently focusing on adaptation of 2D plans of a construction site. The used format is SVG (Scalable Vector Graphics). A cutout of the SVG graphics abstract data model is shown in Figure 5. The representation parameters are derived from the given abstract data model. We also use it for defining classes of perception equivalence.

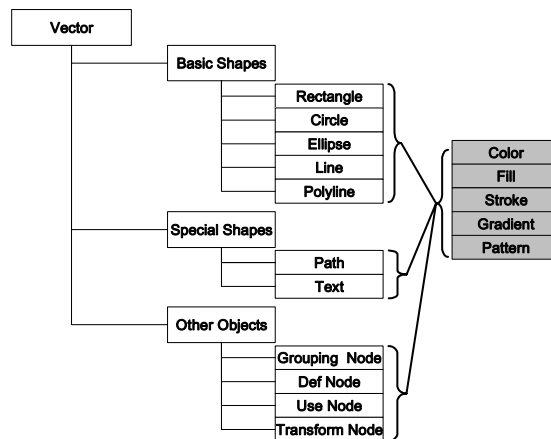

Figure 5 Cutout of abstract data model for SVG

### 5.1.3. Generation of adaptation commands

The generation of adaptation commands step is responsible for creating of commands for the adaptation Execution engine. The implementation of the Execution engine can handle elementary data change operations. These operations are directly derived from the Representation column of the Choosing representation table. This step is quite straightforward and does not need any deeper explanation.

### 5.1.4. Performing the adaptation

After generation of adaptation commands the process of data change itself is started. The data types may be different and we need specialized treatment for each of them. To achieve this plug-in system is used. In this concept we use special plug-ins that implement given interface for adaptation of the data. The architecture is schematically shown in Figure 6. In the Data Recognition Engine the data type is recognized and all data are fetched. In the Analyzer Engine steps Determination of RoI, DoI, representation style and generation of adaptation commands are performed. In the Execution Engine the final data change is performed.

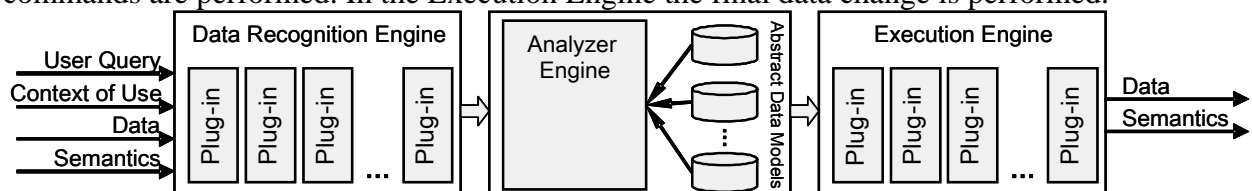

Figure 6 System architecture

## 5.2 Multi user adaptation process

In the multi user adaptation we face several problems that make it more complicated compared to the single user adaptation. In this case there are more users concurrently working on the same data and are collaborating with each other. They have different contexts of use. The most striking example could be usage of devices with various capabilities. One may have color capable display while the other one a black & white only. The adaptation process should be aware of this and should change the representation style so that they get qualitatively same information in order to keep proper level of understanding. This will affect the way of computing the DoI as well as choosing the presentation. Można obrazek ukazuuici kolaboraci vice lidi s nejak vyznaceny problemem by text odlehcil

### 5.2.1. Determining of RoI and DoI

In the multi-user scenario the adaptation pipeline remains virtually (see Figure 3) same as in the single-user scenario with the only difference that there are more quadruples of inputs, one for each user. The resulted DoI will be a maximum of each participant's DoI for given information item.

$$DoI_n = \text{Max}(DoI_{u1}, \dots, DoI_{um})$$

Where  $n$  is the  $n$ -th information item,  $DoI_{u1}$  is the DoI for  $n$ -th information item of user 1 and  $DoI_{um}$  is the DoI for the information item of the  $m$ -th user.

### 5.2.2. Choosing representation

The most complicated part is the choice of representation. The goal is that all users get *qualitatively* same information. A simple modification of the single-user algorithm could be used. This modification selects the minimal equal row from the representation table that matches to all the contexts of use. In Figure 7 this case is displayed. The DoI is the same for all the participants (computed as max of all the DoIs). This means that initially the searching starts at the same row (arrow A). This row matches the context condition by user 1 but not by user 2. The matching rows are pointed by arrows B. In this naive algorithm the bottommost line is selected (arrows C).

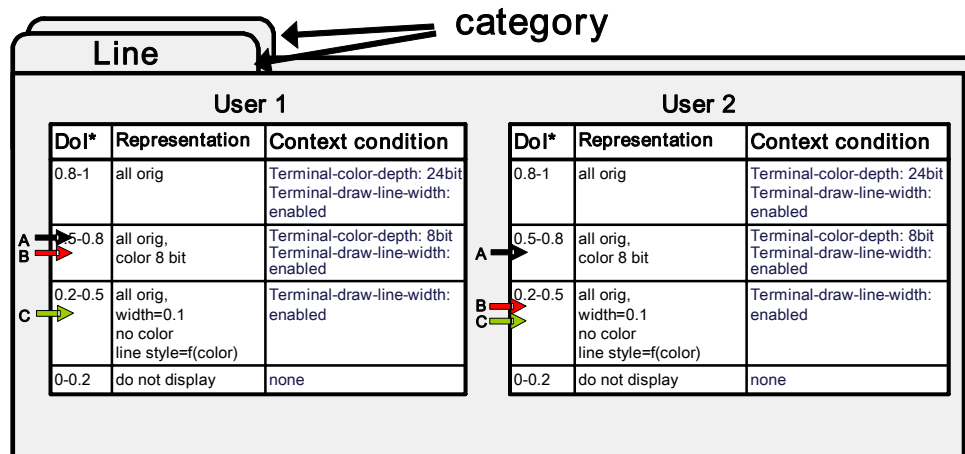

Figure 7 Choosing of representation - naive algorithm

### 5.2.3. Perception model

The imperative that all users must get *qualitatively same information* does not mean that the data must have exactly same representation. In the example in Figure 7 user 1 may preserve the color information (his arrow B) while the user 2 may go to lower in the representation table (his arrow B). This may happen only if the user 2 can get the information expressed by color in other coding. In other words the representation may be different by each user only if there is no loss of information. Otherwise they must use the same way of representation.

We have to define a perception model of the user. Using the perception model we can determine which representation is qualitatively equal to another one. The user's perception is also context dependent. For example object's temperature might be presented by different color or by a sound frequency. If user 1 has a color enabled device while the user 2 doesn't, this is an appropriate way of representation. In case the user 2 is in a noisy environment, this representation is not appropriate any more. *It is context dependent.*

#### 5.2.4. Classes of perception equivalence

We propose a solution that sorts out the representations into categories of the same perception quality. We name these categories classes perception of equivalence.

Definition:

*Two representation styles are in the same class of perception equivalence if and only if they deliver to the user in given context of use the same information.*

The classes are implemented as an extension of the representation table. Each class of equivalence is there implemented as conditional transition between two rows in the table. The condition is a function of context of use typically implemented as a list of context conditions that must be fulfilled.

Using the classes of perception equivalence we achieve a state where each collaborating client has a different adaptation that fully benefits from the capabilities of device used (context of use) and simultaneously ensures same level of cognition for all the users.

Dol* range	Representation	Context condition
0.8-1	all orig	Terminal-color-depth: 24bit Terminal-draw-line-width: enabled
0.5-0.8	all orig, color 8 bit	Terminal-color-depth: 8bit Terminal-draw-line-width: enabled
0.2-0.5	all orig, width=0.1 no color line style=f(color)	Terminal-draw-line-width: enabled
0-0.2	do not display	none

Figure 8 Implementation of classes of perception equivalence

## 6. CONCLUSION

We have analyzed the problems of collaborative work in mobile environment in conjunction with adaptation process. Here presented algorithm can deal with the context based adaptation in combination with real-time data sharing. This is an improvement of until now separate algorithms for data sharing and adaptation. We propose a solution that enables to find a compromise between not adapting the shared data at all (this will in fact disable the presentation of data on some PDAs) and adapting the data of all users according to the worst case. Our collaborative adaptation algorithm use so called classes of perception equivalences to allow individual adaptation for each collaborating user and at the same time prevent the misunderstanding during collaboration on differently adapted data. We have made a pilot implementation of the algorithm within the MUMMY [MUMMY] project also using experiences from the MAP[MAP] project. In the named project the plug-in architecture has been implemented and the functionality has been tested on adaptation of complex 3D (VRML) scenes for use on the PDA devices. We have achieved a speed-up factor of the rendering on the mobile device by factor of 80 to 100% (depending on the current scene complexity).

## REFERENCES

- [Tazari 2003] M. Tazarid, M. Grimm, M. Finke, *Modelling User Context*, Proc. HCI International 2003, Mahwah, New Jersey : Lawrence Erlbaum, 2003, pp. 293-297
- [Klima 2002] M. Klíma, Z. Míkovec, P. Slavík, *Manipulation of Complex 2D/3D Scenes on Mobile Devices*, Proc 2nd IASTED International Conference: Visualization, Imaging, and Image Processing. Anaheim, Acta Press, 2002, p. 161-166. ISBN 0-88986-354-3.

- [Myers 1998] B. A. Myers, H. Stiel, R. Gargiulo, *Collaboration using multiple PDAs connected to a PC*, Proceedings of the 1998 ACM conference on Computer supported cooperative work, pp. 285 - 294
- [Blair 2000] G. S. Blair, G. Coulson, L. Blair, M. Clarke, F. Costa, H. Duran, N. Parlavantzas, K. Saikoski, *A Principled Approach to Supporting Adaptation in Distributed Mobile Environments*, International Symposium on Software Engineering for Parallel and Distributed Systems (PDSE 2000)
- [Rauschenbach 1998] Uwe Rauschenbach, *Progressive Image Transmission Using Levels of Detail and Regions Of Interest*, Proc. IASTED Conf. on Computer Graphics and Imaging - CGIM'98, Halifax, Nova Scotia, Canada, June 1-4, 1998
- [MUMMY] Mummy (IST-2001-37365): Mobile knowledge management.  
<http://mummy.intranet.gr>
- [MAP] MAP: Multimedia workplace of the future <http://www.map21.de>
- [Grønbæk 1994] K. Grønbæk, J.A. Hem, O.L. Madsen, L. Sloth, *Cooperative Hypermedia Systems: A Dexter-based architecture*. Communications of the ACM 37, 2 , pp. 64-75, 1994
- [Hicks 2001] Hicks, David L., and Wiil, Uffe K, *Towards Collaborative Design in an Open Hypermedia Environment*, Proceedings of the Sixth International Conference on CSCW in Design (CSCWD 2001), London, Ontario, Canada, pp. 181-189, 2001